

MODEL 295 Capacitor Trip Device

- Discharge Manually
or with a Control Device
- 120 and 240 Volt Versions

DESCRIPTION

The **Model 295 Capacitor Trip Device** is used to trip circuit breakers by using the stored energy in a capacitor. The capacitor is kept at full charge during normal operation by a half-wave silicon rectifier which draws its energy from the power line.

When completely discharged, the Model 295 draws approximately 10 amps from the line in the first half cycle, 3 amps the second half cycle and 1 amp from the third. Continuous current required to keep the capacitor charged is less than 5 milliams.

The capacitor holds sufficient charge to trip the breaker for at least 12 seconds after the charging voltage is removed. However, on most fault conditions, some voltage is still present, so the Model 295 is designed so that 65% of normal voltage gives sufficient charge to trip the breaker.

A low-energy lamp, connected in parallel with the storage capacitor, gives a visual indication when the voltage charge is 85 volts or more on the 120V version and 170 volts or more on the 240V version.

TYPICAL APPLICATION

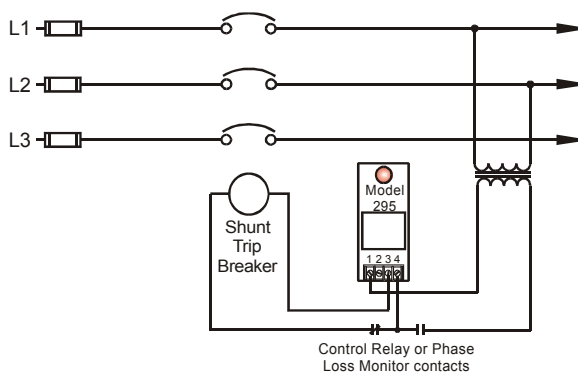

SPECIFICATIONS

MODEL	295-120	295-240
Nominal input voltage	120 VAC	240 VAC
Input voltage range	90 - 120 VAC	190 - 240 VAC
Output voltage	170 VDC	339VDC
Frequency range	50 - 400 Hz	
Operating temperature	- 40° to +131° F	
Humidity tolerance	0-97% w/o condensation	
Case material	20 Gauge CRS	
Mounting	Surface	
Weight	2 lbs.	

DIMENSIONS

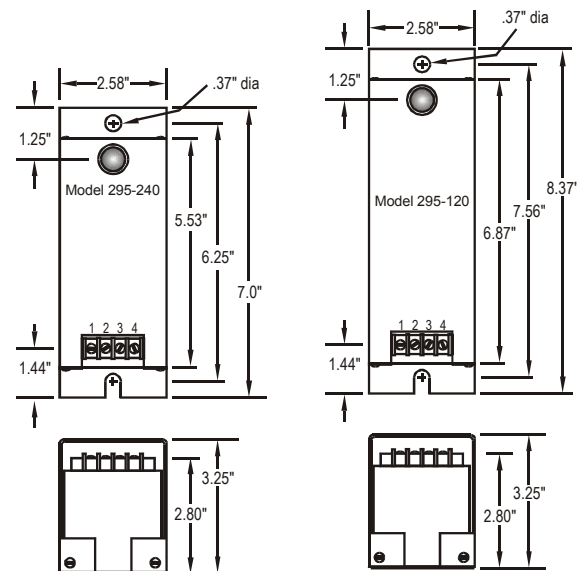

MODEL 295 Capacitor Trip Device

READ ALL INSTRUCTIONS BEFORE INSTALLING, OPERATING OR SERVICING THIS DEVICE.
KEEP THIS DATA SHEET FOR FUTURE REFERENCE.

GENERAL SAFETY

POTENTIALLY HAZARDOUS VOLTAGES ARE PRESENT AT THE TERMINALS OF THE MODEL 295.
ALL ELECTRICAL POWER SHOULD BE REMOVED WHEN CONNECTING OR DISCONNECTING WIRING.
THIS DEVICE SHOULD BE INSTALLED AND SERVICED BY QUALIFIED PERSONNEL.

Installation Instructions

INSTALLATION

Connect the control wiring to the terminals with the contact markings (refer to the diagram on the unit). Apply power.

ADJUSTMENT

No calibration or adjustments are needed for this device.

TROUBLESHOOTING

Should the Model 295 Capacitor Trip Device fail to operate, check all connections. Verify that power is present, and check all fuses. Should problems persist, contact the factory at 800-862-2875 for assistance.

TYPICAL APPLICATION

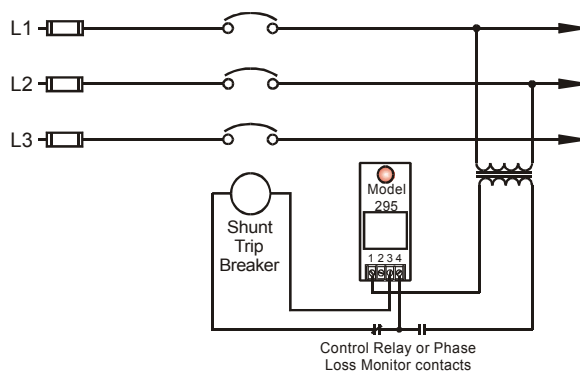

The following graph shows the energy from the Model 295 in Watt-Seconds (WS).

The horizontal axis represents the input voltage (VAC) with the corresponding output voltage (VDC).

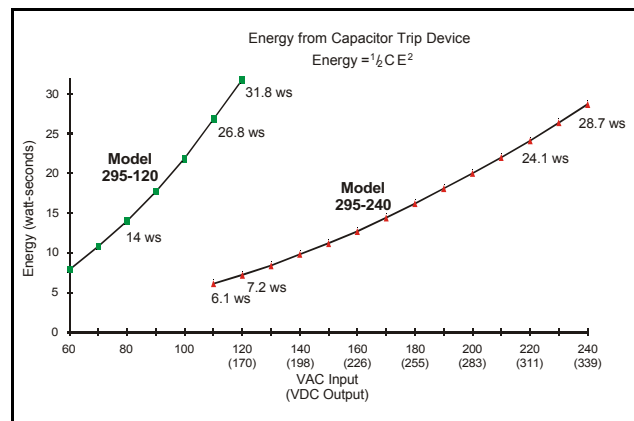

WARRANTY

The **Model 295 Capacitor Trip Device** is warranted to be free from defects in materials and workmanship for one year. Should this device fail to operate, we will repair or replace it for one year from the date of purchase. For complete warranty details, see the *Terms and Conditions of Sales* page in the front section of the Time Mark catalog.